

Agri-Fab®

**OWNERS
MANUAL**

Model No.

45-02173

190-521A-100

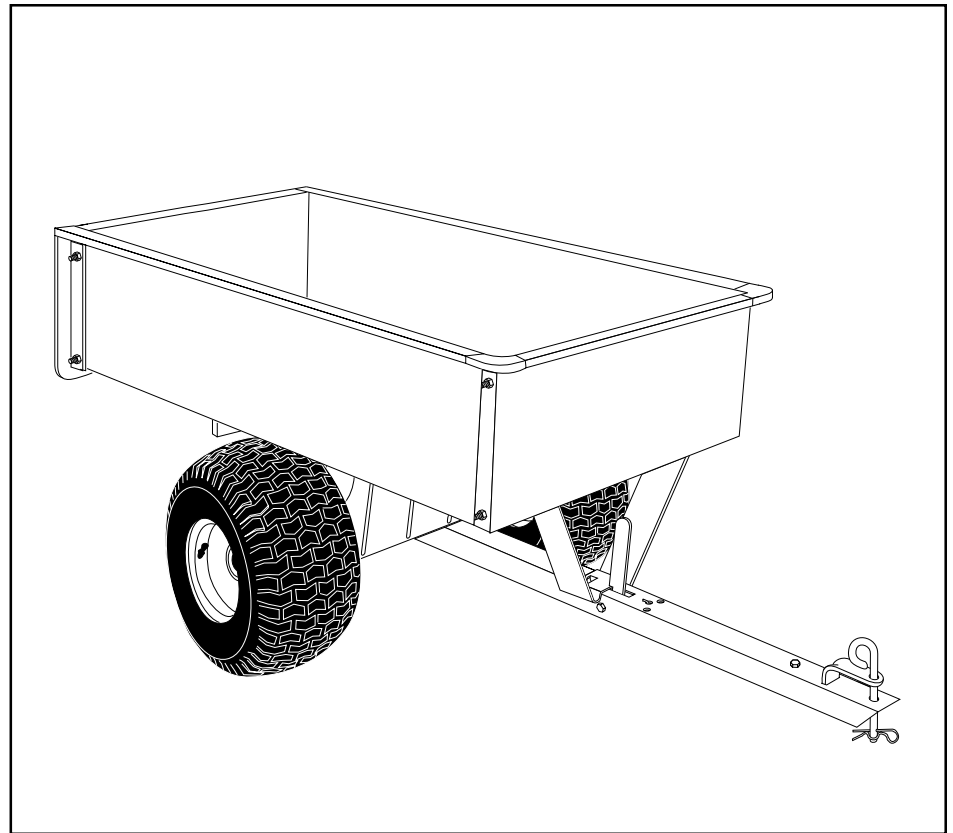

**SUPER 17
ATV CART**

CAUTION:
Read Rules for
Safe Operation
and Instructions
Carefully

- Assembly
- Operation
- Maintenance
- Repair Parts

SpeedPart *the fastest way to purchase parts* www.speedepart.com

SAFETY RULES

Remember, any power equipment can cause injury if operated improperly or if the user does not understand how to operate the equipment. Exercise caution at all times when using power equipment.



LOOK FOR THIS SYMBOL TO POINT OUT IMPORTANT SAFETY PRECAUTIONS. IT MEANS -- ATTENTION! BECOME ALERT! YOUR SAFETY IS INVOLVED.



CAUTION: VEHICLE BRAKING AND STABILITY MAY BE AFFECTED WITH THE ADDITION OF AN ACCESSORY OR AN ATTACHMENT. BE AWARE OF CHANGING CONDITIONS ON SLOPES.

Exercise caution at all times when using power equipment.

- Read this owners manual before attempting to assemble or operate the cart.
- Read the vehicle owners manual and know how to operate your tractor, before using the cart attachment.
- Do not at any time carry passengers in this cart. It has not been designed to carry passengers.
- Never allow children to operate the tractor or the cart attachment.
- Do not allow adults to operate the tractor or cart attachment without proper instructions.
- Always begin with the transmission in first (low) and gradually increase speed as conditions permit.
- Tow the cart at reduced speed over rough terrain and hillsides or near creeks and ditches to prevent tipping over and loss of control. Do not drive too close to a creek or ditch.
- Vehicle braking and stability may be affected with the attachment of this cart. Do not fill cart to maximum weight capacity without checking the capability of the towing vehicle to safely pull and stop with the cart attached.
- Before operating vehicle on any grade (hill) refer to the safety rules in the vehicle owner's manual concerning safe operation on slopes. Refer also to the slope guide on page 9 of this manual. **Stay off steep slopes!**
- Do not tow this cart on highways or on public thoroughfares.
- Maximum towing speed is 20 m.p.h.
- Follow maintenance and lubrication instructions as outlined in this manual.

CARTON CONTENTS

- | | | |
|------------------------|-----------------------------------|----------------------|
| 1. Tailgate Guides (2) | 5. Latch Stand Bracket | 10. Axle Bracket (2) |
| 2. Corner Caps (2) | 6. Tailgate Reinforcement Bracket | 11. Axle |
| 3. Latch Lock Lever | 7. Tailgate | 12. Tongue |
| 4. Hitch Bracket | 8. Front Panel | 13. Cart Body (2) |
| | 9. Wheel Support | 14. Wheels (2) |

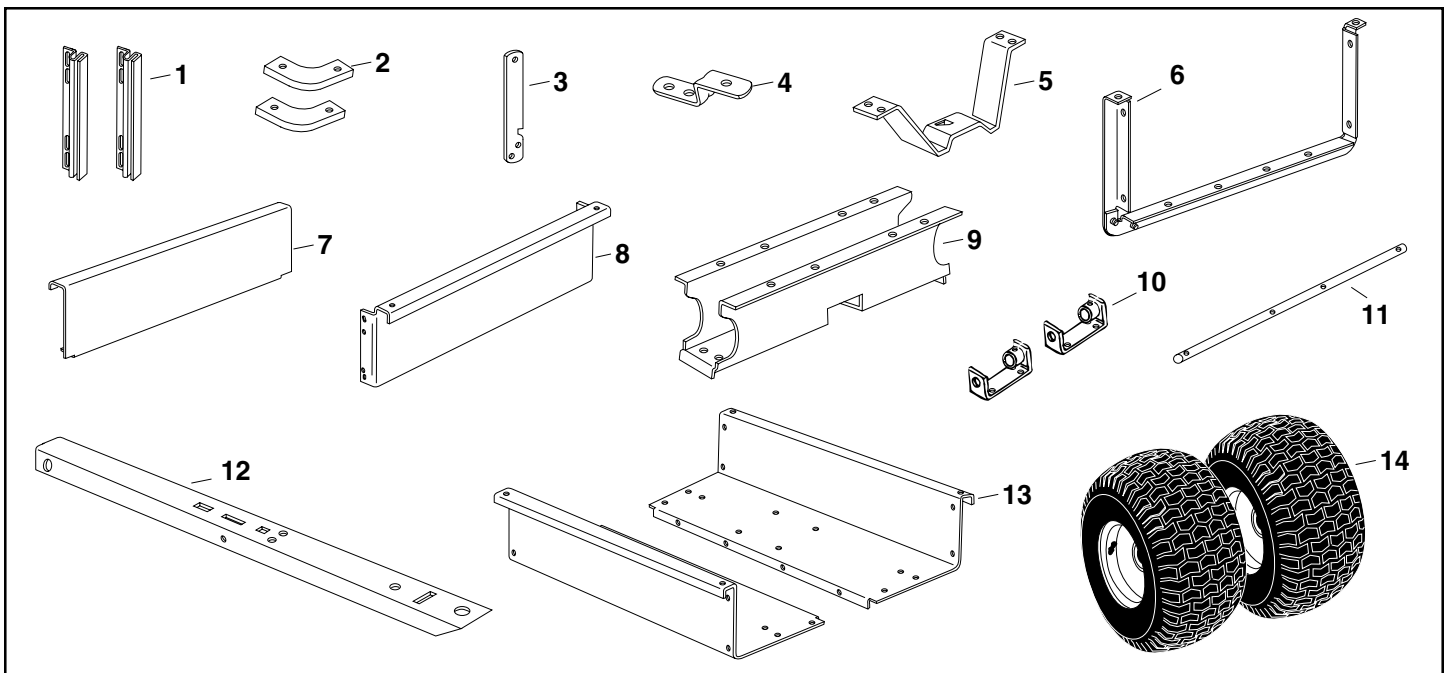

CARTON CONTENTS

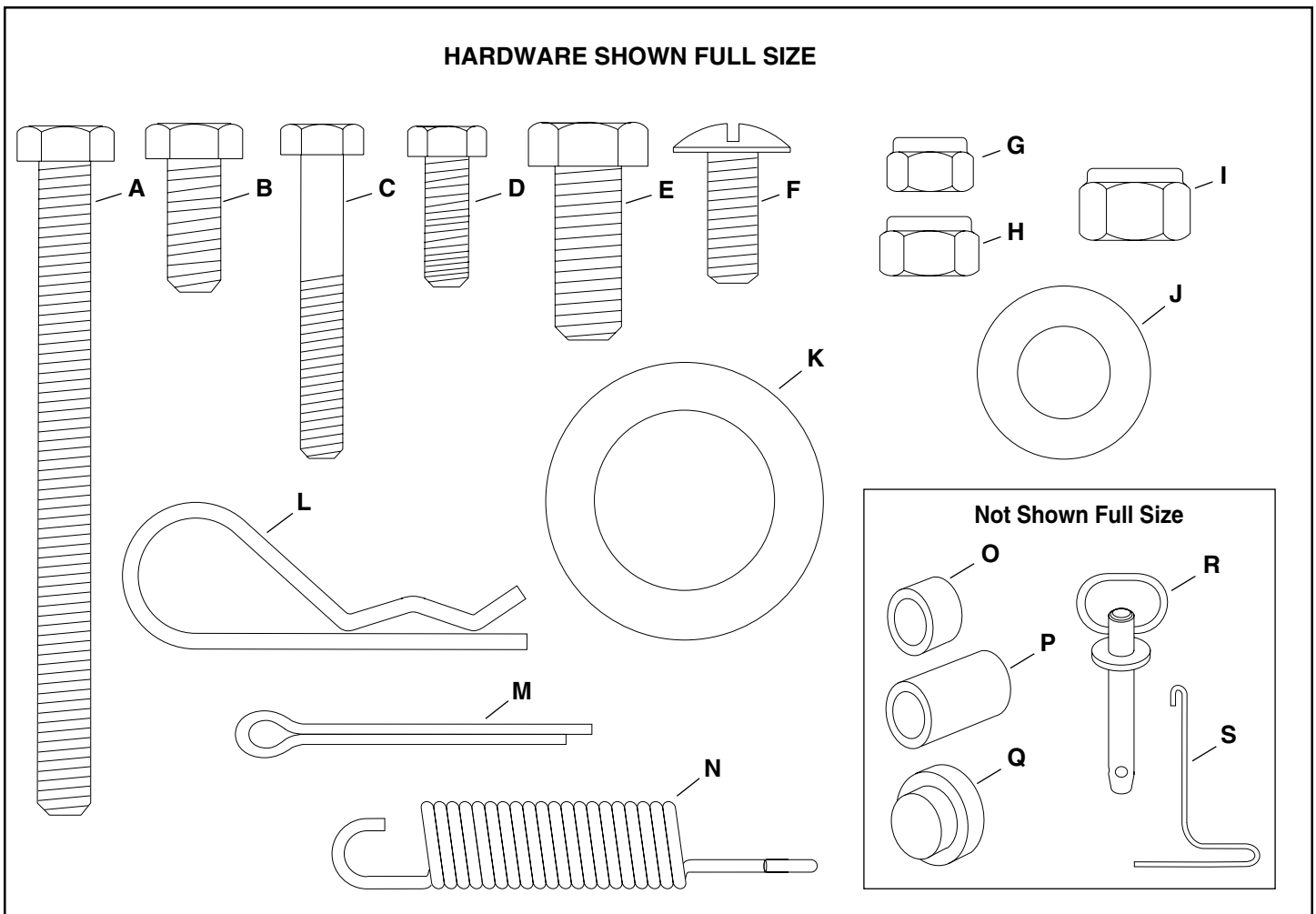

HARDWARE PACK

| REF. | DESCRIPTION | QTY. |
|------|--------------------------------------|------|
| A | Hex Bolt, 5/16" x 3-3/4" | 1 |
| B | Hex Bolt, 5/16" x 3/4" | 8 |
| C | Hex Bolt, 1/4" x 1-3/4" | 2 |
| D | Hex Bolt, 1/4" x 3/4" | 24 |
| E | Hex Bolt, 3/8" x 1" | 1 |
| F | Sl. Truss Hd. Bolt, 5/16" x 3/4" Lg. | 12 |
| G | Nylock Nut, 1/4" | 26 |
| H | Nylock Nut, 5/16" | 23 |
| I | Nylock Nut, 3/8" | 1 |
| J | Flat Washer, 1/2" | 1 |
| K | Flat Washer, 1" | 4 |
| L | Hair Cotter Pin, 3/32" | 1 |
| M | Cotter Pin, 1/8" x 1-1/2" Lg. | 2 |
| N | Spring | 1 |
| O | Spacer Tube (Short) | 2 |
| P | Spacer Tube (Long) | 2 |
| Q | Hub Cap | 2 |
| R | Hitch Pin | 1 |
| S | Spring Puller Tool | 1 |

ASSEMBLY INSTRUCTIONS

TOOLS REQUIRED FOR ASSEMBLY

- (1) Screwdriver
- (1) Pliers
- (2) 7/16" Wrenches
- (1) 1/2" Wrench
- (2) 9/16" Wrenches
- (1) Grease Gun

1. Remove the hardware pack and all loose parts from the carton. Be sure the carton is empty before discarding.
2. Lay out all the parts and hardware as shown on pages 2 and 3.



CAUTION

DO NOT LEAVE THE CART UNATTENDED IN UPRIGHT POSITION DURING ASSEMBLY. A FALLING CART CAN CAUSE PERSONAL INJURY! PAY CLOSE ATTENTION TO THE STABILITY OF THE CART WHILE IT REMAINS IN AN UPRIGHT POSITION. FOR BEST STABILITY, ASSEMBLE ON A SMOOTH, LEVEL SURFACE.

3. Position cart body halves upright on a smooth level surface such as a garage floor or a paved driveway. See figure 1.
4. Assemble halves together using four 1/4" x 3/4" hex bolts and 1/4" nylock nuts as shown in figure 1. **Do not tighten at this time.**

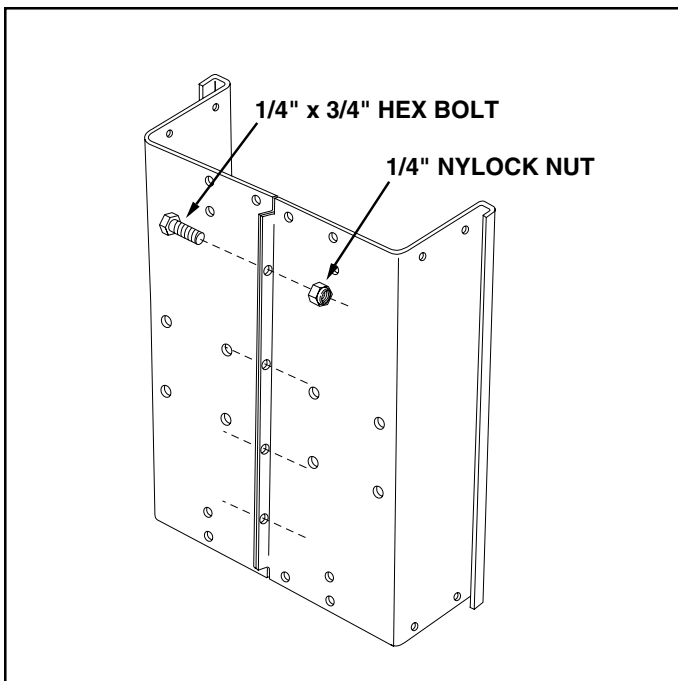

FIGURE 1

5. Position the tailgate reinforcement bracket on outside of cart as shown in figure 2. Assemble to the bottom of the cart body using four 5/16" x 3/4" truss head bolts and 5/16" nylock nuts. **Do not tighten yet.** See figure 2.
6. Position the tailgate guides on the inside of the cart bodies with guide channels to the front as shown in figure 2. Assemble using four 1/4" x 3/4" hex bolts and 1/4" nylock nuts. **Do not tighten yet.** See figure 2.

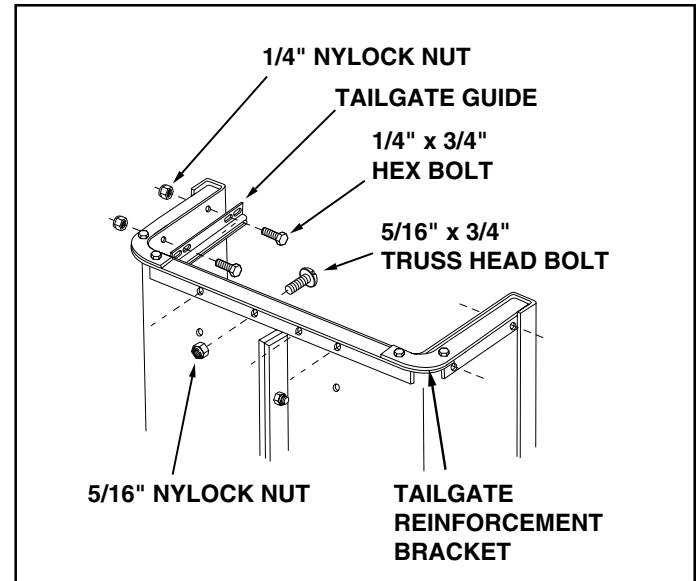

FIGURE 2

7. At this time, with the cart body halves pulled together, **tighten** the four truss head bolts assembled in step 5 and then the four hex bolts assembled in step 6. Leave loose for now the bolts that were assembled in step 4.
8. Carefully reverse the position of the cart so that it rests on the end with the tailgate reinforcement bracket, as shown in figure 3. Proceed with the assembly steps which follow.

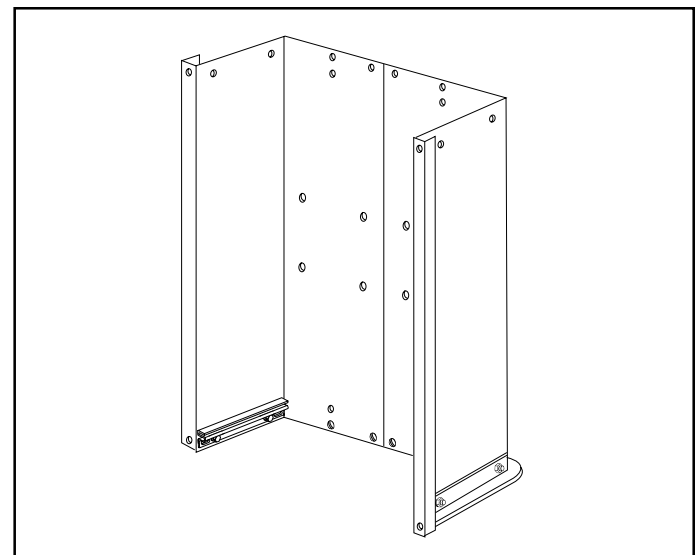

FIGURE 3

9. Assemble the front panel over the end of the cart using six 1/4" x 3/4" hex bolts and 1/4" nylock nuts as shown in figure 4. Leave two holes in the bottom of the panel empty as shown. With the cart body halves pulled together, **tighten** the bolts in the bottom of the front panel, then **tighten** the bolts in the sides. See figure 4.

10. At this time **tighten** the bolts assembled in step 4, which fasten the bottom of the cart together.

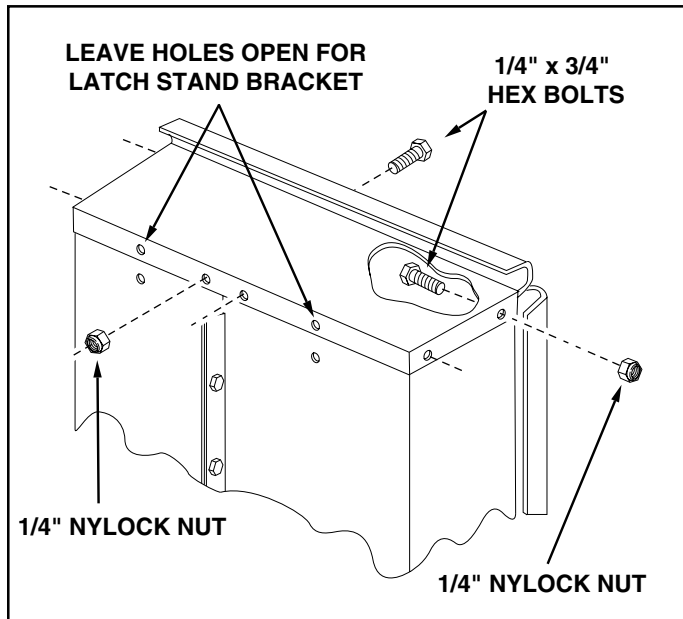

FIGURE 4

11. Assemble the wheel support to the cart using eight 5/16" x 3/4" truss head bolts and 5/16" nylock nuts as shown in figure 5. Heads of bolts go on the inside of the cart. **Tighten**.

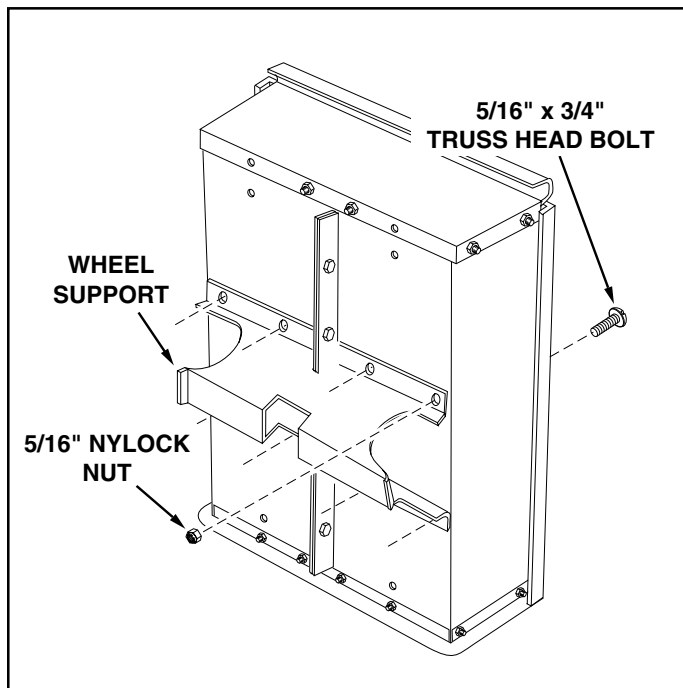

FIGURE 5

12. Turn the latch stand bracket so that the aligning tab is at the rear (bottom) of the bracket. Assemble the latch stand bracket to the cart using four 1/4" x 3/4" hex bolts and 1/4" nylock nuts. **TIGHTEN**. See figure 6.

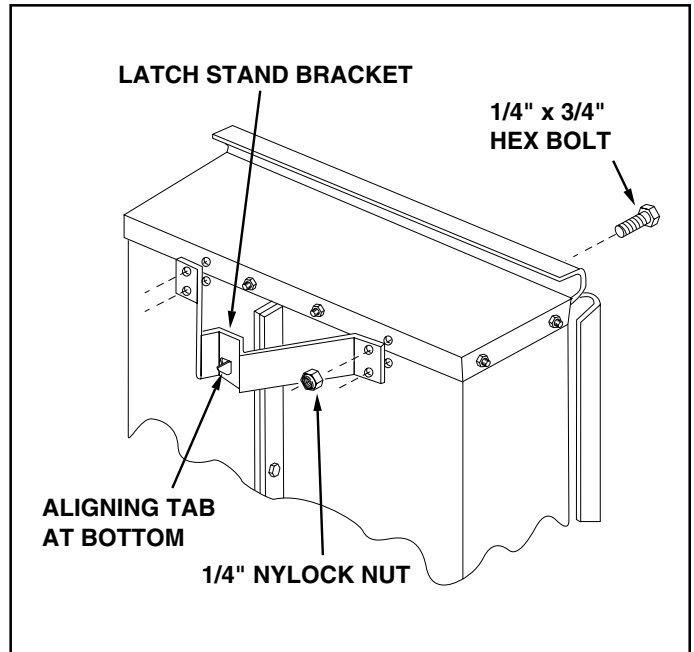

FIGURE 6

13. Assemble the two corner caps to the front corners of the cart using four 1/4" x 3/4" hex bolts and 1/4" nylock nuts. Also assemble two 1/4" x 3/4" hex bolts and 1/4" nylock nuts to the two rear corners of the cart. **Tighten**. See figure 7.

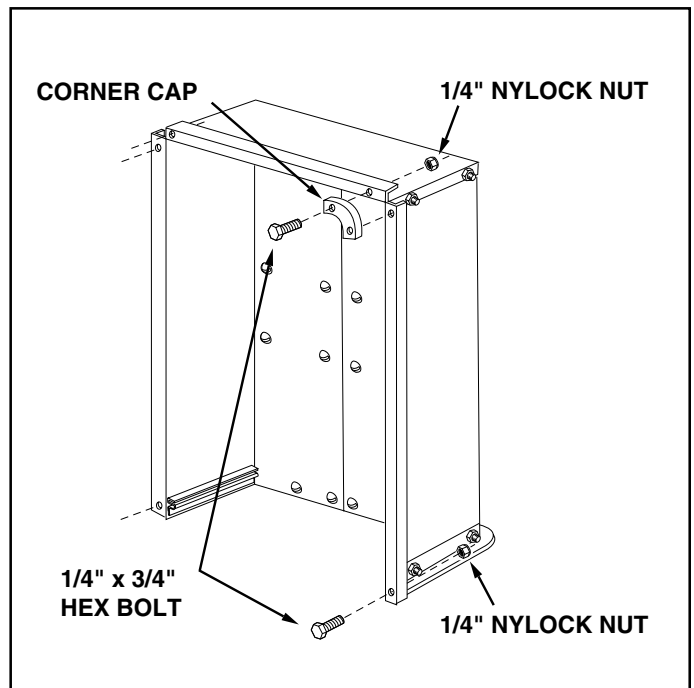

FIGURE 7

14. To prevent accidental tipping during the following assembly procedures, lower the cart to rest upside down on its top flanges, so that the wheel support is facing up. See figure 8.
15. Assemble both axle brackets to the wheel support using eight 5/16" x 3/4" hex bolts and 5/16" nylock nuts. Place the welded tubes to the inside. See figure 8.

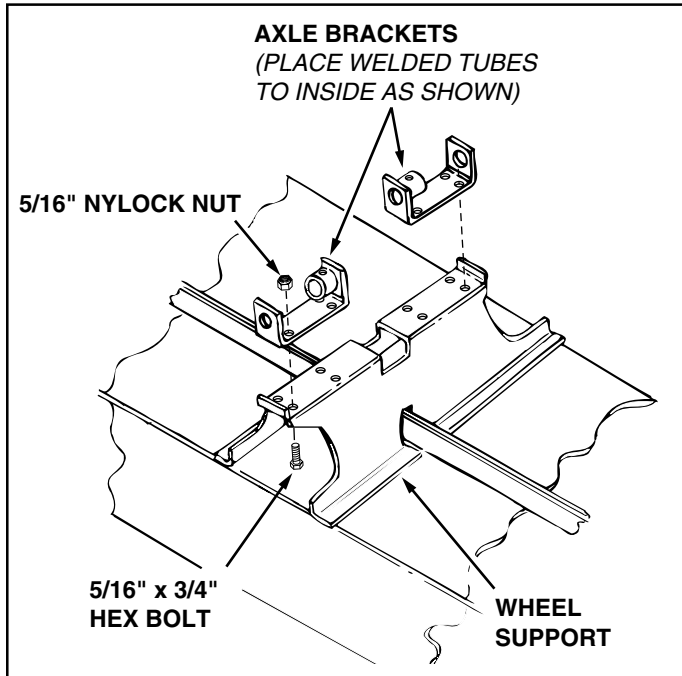

FIGURE 8

16. Place the tongue, open side facing up, onto the wheel support and the latch stand bracket. See figure 10.
17. Place a long spacer tube on each side of the tongue and assemble the axle through the wheel support, the two spacer tubes and the tongue. Secure the axle using two 1/4" x 1-3/4" hex bolts and 1/4" nylock nuts. **Tighten.** See figure 9.

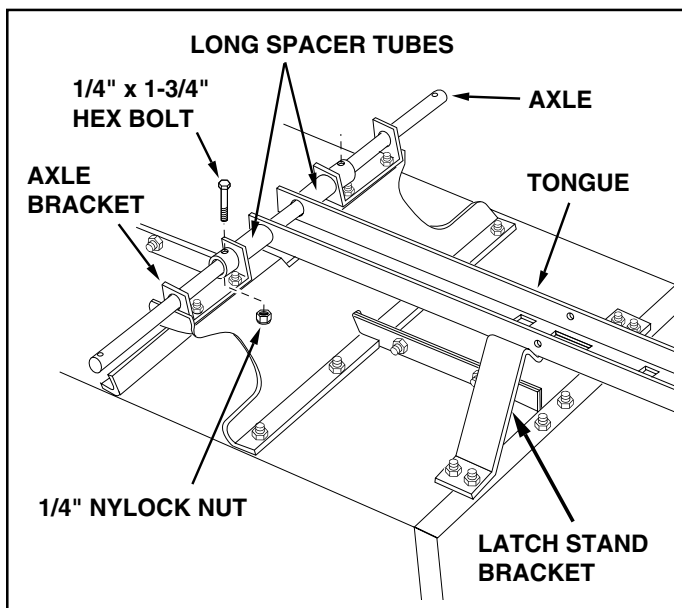

FIGURE 9

18. Place the latch lock lever through the slot in the tongue as shown in figure 10. Assemble the 5/16" x 3-3/4" hex bolt through the tongue, the lever and two 5/16" nylock nuts (one on each side of the lever). Assemble a 5/16" nylock nut onto the end of the bolt so that the bolt has no end play, but can rotate freely. **Tighten** the two 5/16" nylock nuts against the sides of the latch lock lever so that the lever is centered in the slot. See figure 10.

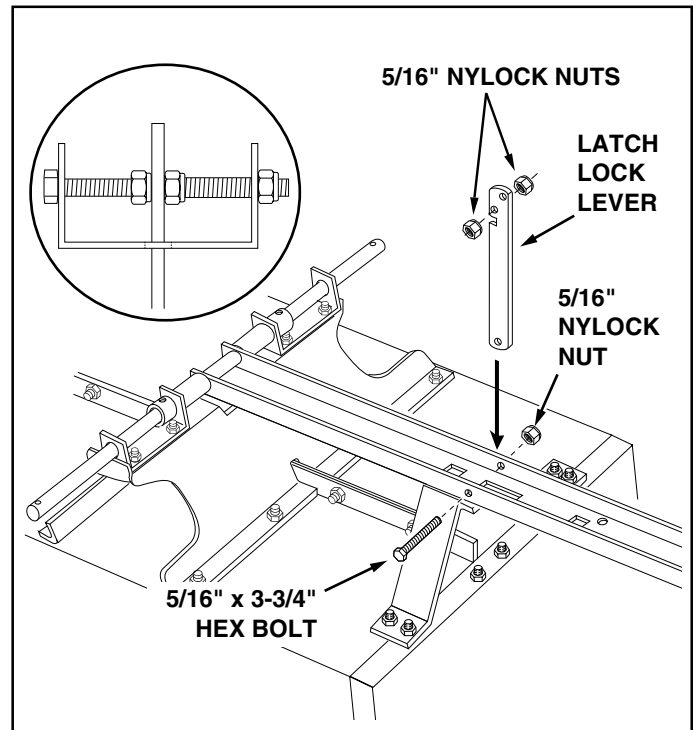

FIGURE 10

19. Hook the **short** end of the spring into the hole in the latch lock lever. Use the spring puller tool to hook the **long** end of the spring into the square hole in the tongue. The spring puller tool can be stored when finished. See figure 11.

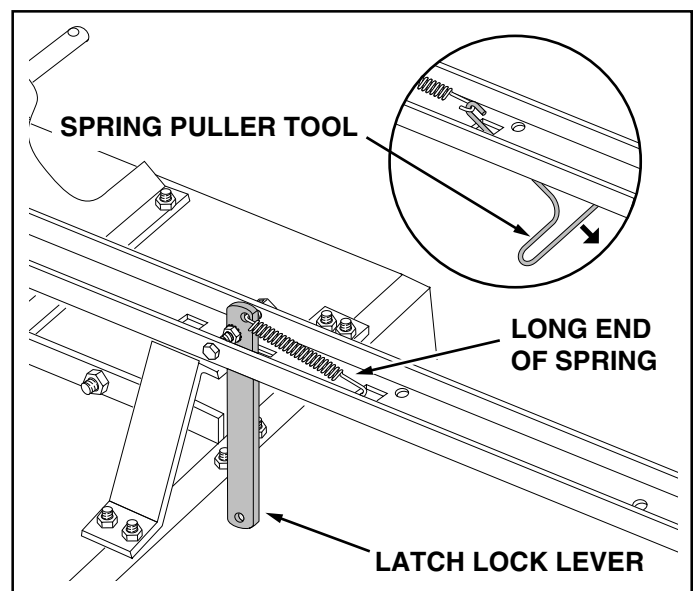

FIGURE 11

20. Assemble a short spacer tube, a 1" flat washer, a wheel (valve stem facing out), and another 1" flat washer onto the axle. Secure with a cotter pin, spreading the ends so that a hub cap can fit over the pin. Assemble the hub cap by pressing it onto the flat washer. Repeat on other end of axle. See figure 12.

IMPORTANT: Fill wheel hub with grease after wheel is assembled onto axle.

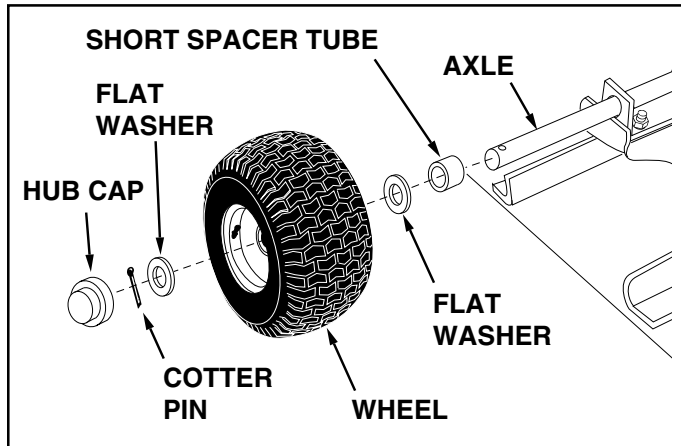

FIGURE 12

IMPORTANT: Make sure the tongue is securely locked to the latch stand bracket by the latch lock lever.

21. Turn the cart over so that it rests right side up on its wheels.
22. Assemble the end of the hitch bracket with two holes down through the slot at the front of the drawbar tongue. Fasten it to the tongue using the 3/8" x 1" hex bolt and 3/8" nylock nut. **Tighten.** See figure 13.
23. Assemble the hitch pin and 1/2" flat washer to the tongue and hitch bracket and secure with the 3/32" hair cotter pin. See figure 13.

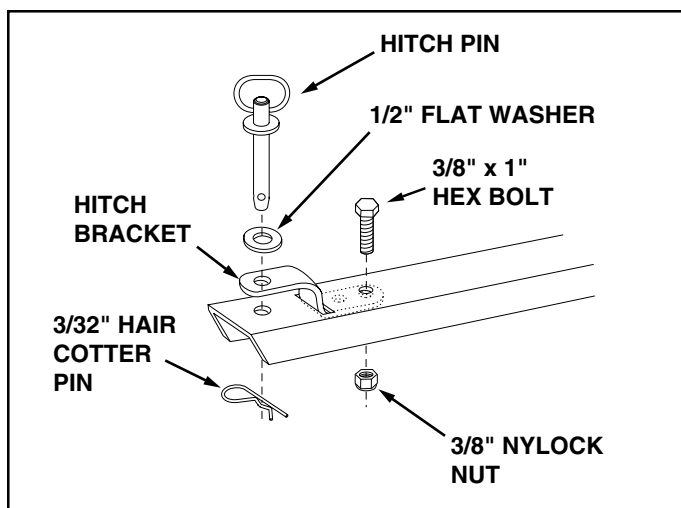

FIGURE 13

24. Place the tailgate down into the tailgate guides so that the holes in the bottom lip of tailgate fit over the slotted head screws in the bottom of the cart.

OPERATION



CAUTION: VEHICLE BRAKING AND STABILITY MAY BE AFFECTED WITH THE ADDITION OF AN ACCESSORY OR AN ATTACHMENT. BE AWARE OF CHANGING CONDITIONS ON SLOPES.

1. Refer to the vehicle owners manual for instructions on safe operation on slopes.
2. Use the slope guide provided on page 9 of this manual to determine if slope angle is too steep for safe operation.
3. For best handling and traction, distribute the weight of the load evenly in the cart.
4. Always test to make sure your tractor has adequate towing and braking capabilities whenever hauling a substantial amount of weight in your cart. Use extra caution when operating on slopes.

NOTE

DO NOT EXCEED WEIGHT CAPACITY OF CART
(See the specifications on this page for each model)
One cubic foot of dirt weighs approximately 150 lbs.

5. To dump material from the cart, remove the tailgate by lifting it straight up and out from between the guides. Release the spring latch on the tongue by pulling the latch lock handle forward, away from the cart. The cart bed will then tilt backwards to empty its contents. After emptying, pull the front of the bed down toward the cart tongue until the latch snaps into place. Replace the tailgate if desired.
6. The maximum towing speed for this cart is 20 m.p.h.



CAUTION: TO AVOID POSSIBLE INJURY, BEFORE RELEASING THE LATCH BE SURE THAT NO ONE IS NEAR THE CART.

MAINTENANCE

1. At the beginning of each season, using a light machine oil, lubricate the latch, the latch pivot bolt, and the area of the axle where the draw bar tongue pivots .
2. At the beginning of each season, grease the wheel bearings. Apply grease through the grease zerk in the wheel hub.
3. Check periodically for loose bolts.
4. Keep tires filled. Do not exceed maximum tire pressure of 10 Lbs.

SPECIFICATIONS FOR "ATV" DUMP CART MODEL 45-02173 & 190-521A-100

Tires: 18.0" x 9.5" Pneumatic

Axle: 1.0" Dia. Steel

Capacity: Up to 1700 Lbs. Max.

Approx. Sh. Wt. 195 Lbs.

SLOPE GUIDE

(Keep this sheet in a safe place for future reference.)

Use this guide to determine if a slope is safe for the operation of your tractor and cart. Refer also to the instructions in your vehicle owners manual.

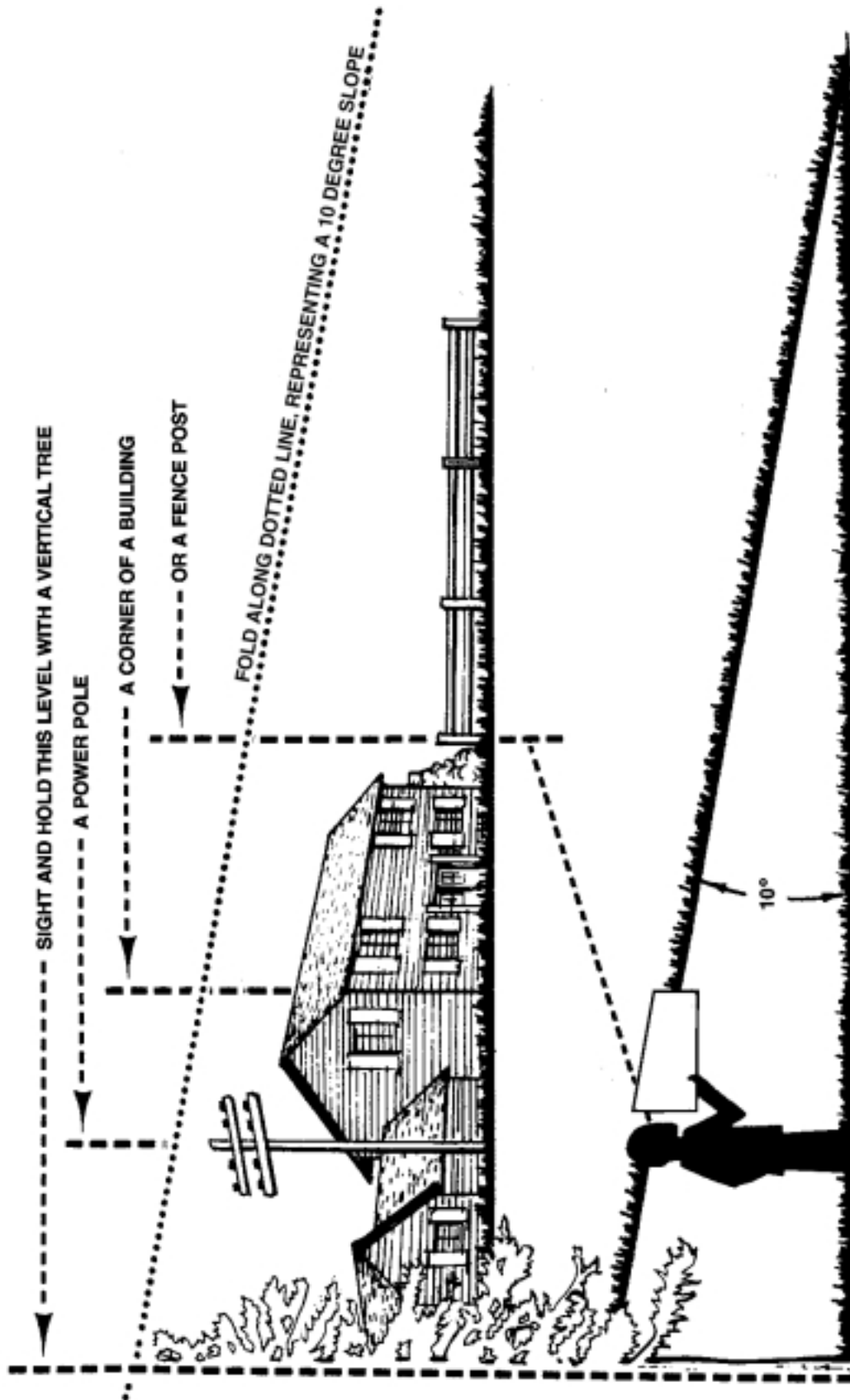

CAUTION: DO NOT OPERATE YOUR TRACTOR AND CART ON A SLOPE IN EXCESS OF 10 DEGREES. BE SURE OF YOUR TRACTOR'S TOWING AND BRAKING CAPABILITIES BEFORE OPERATING ON A SLOPE. AVOID ANY SUDDEN TURNS OR MANEUVERS WHILE ON A SLOPE.



REPAIR PARTS FOR CART MODELS 45-02173 & 190-521A-100

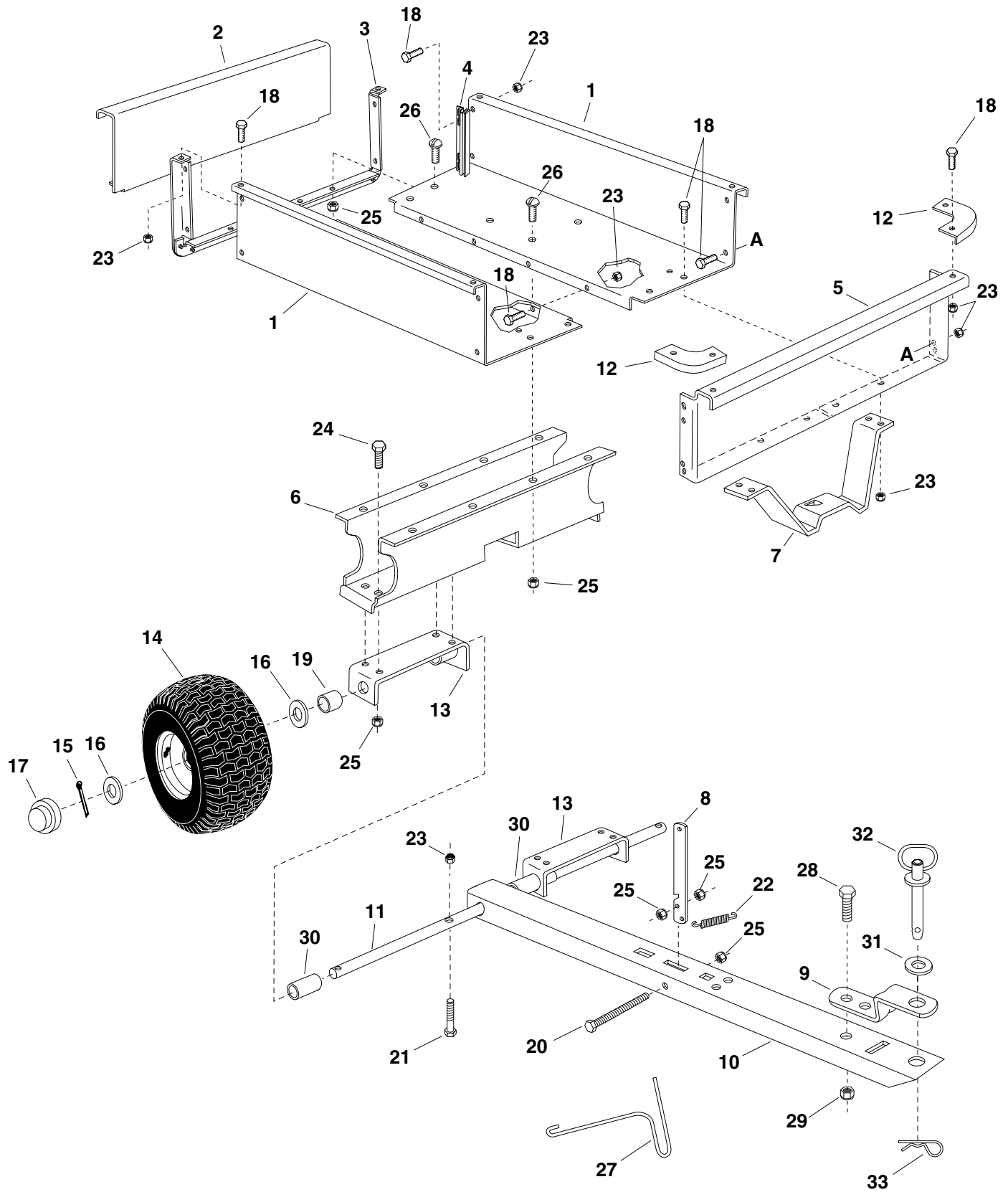

REPAIR PARTS LIST FOR CART MODELS 45-02173 & 190-521A-100

| REF. NO. | PART NO. | DESCRIPTION | 45-02173 | 190-521A-100 |
|----------|-----------|---|----------|--------------|
| 1 | 23984 | Cart Body | 2 | 2 |
| 2 | 23504 | Tailgate | 1 | 1 |
| 3 | 62457 | Tailgate Reinforcement Bracket | 1 | 1 |
| 4 | 23548 | Guide, Tailgate | 2 | 2 |
| 5 | 23490 | Front Panel | 1 | 1 |
| 6 | 23821 | Wheel Support | 1 | 1 |
| 7 | 24757 | Latch Stand Bracket | 1 | 1 |
| 8 | 24498 | Latch Lock Lever | 1 | 1 |
| 9 | 23014 | Hitch Bracket | 1 | 1 |
| 10 | 24756 | Tongue (Draw Bar) | 1 | 1 |
| 11 | 24462 | Axle, Wheel 1" Dia. | 1 | 1 |
| 12 | 23484 | Cap, Front Corner | 2 | 2 |
| 13 | 62359 | Axle Bracket Assembly | 2 | 2 |
| 14 | 48906 | Wheel, 18.0" x 9.5" | 2 | 2 |
| 15 | 43093 | Cotter Pin, 1/8" Dia. x 1-1/2" | 2 | 2 |
| 16 | 43601 | Washer, Flat 1.032" | 4 | 4 |
| 17 | 43014 | Hub Cap | 2 | 2 |
| 18 | 43012 | Hex Bolt, 1/4-20 x 3/4" * | 24 | 24 |
| 19 | 45132 | Spacer Tube (Short) | 2 | 2 |
| 20 | 47407 | Hex Bolt, 5/16-18 x 3-3/4" | 1 | 1 |
| 21 | 1509-69 | Hex Bolt, 1/4-20 x 1-3/4" * | 2 | 2 |
| 22 | 47408 | Spring | 1 | 1 |
| 23 | 47189 | Nylock Nut, 1/4-20 Thread * | 26 | 26 |
| 24 | 43182 | Hex Bolt, 5/16-18 x 3/4" Lg.* | 8 | 8 |
| 25 | 47810 | Nylock Nut, 5/16" Thread | 23 | 23 |
| 26 | 43814 | Slit. Truss Hd. Bolt, 5/16-18 x 3/4" Lg.* | 12 | 12 |
| 27 | 47622 | Spring Puller Tool | 1 | 1 |
| 28 | 43001 | Hex Bolt, 3/8-16 x 1" Lg. * | 1 | 1 |
| 29 | HA21362 | Nylock Nut, 3/8-16 Thread * | 1 | 1 |
| 30 | 44678 | Spacer Tube (Long) | 2 | 2 |
| 31 | R19171616 | Flat Washer, 17/32" x 1" | 1 | 1 |
| 32 | 43884 | Pin, Hitch | 1 | 1 |
| 33 | 43343 | Hair Cotter Pin, 3/32" | 1 | 1 |
| | 49173 | Owners Manual | 1 | 1 |

* Purchase Common Hardware Locally

SpeedEPart *the fastest way to purchase parts* www.speedepart.com

For Agri Fab Discount Parts Call 606-678-9623 or 606-561-4983

SpeedPart *the fastest way to purchase parts* www.speedepart.com

REPAIR PARTS
303 West Raymond
Sullivan, IL. 61951
217-728-8388
www.agri-fab.com

www.mymowerparts.com